

# Jacket heaters for 1000L IBC containers with tubular steel frame. **One heating zone.** **Digital display** electronic temperature controller, **remote wall mounting**

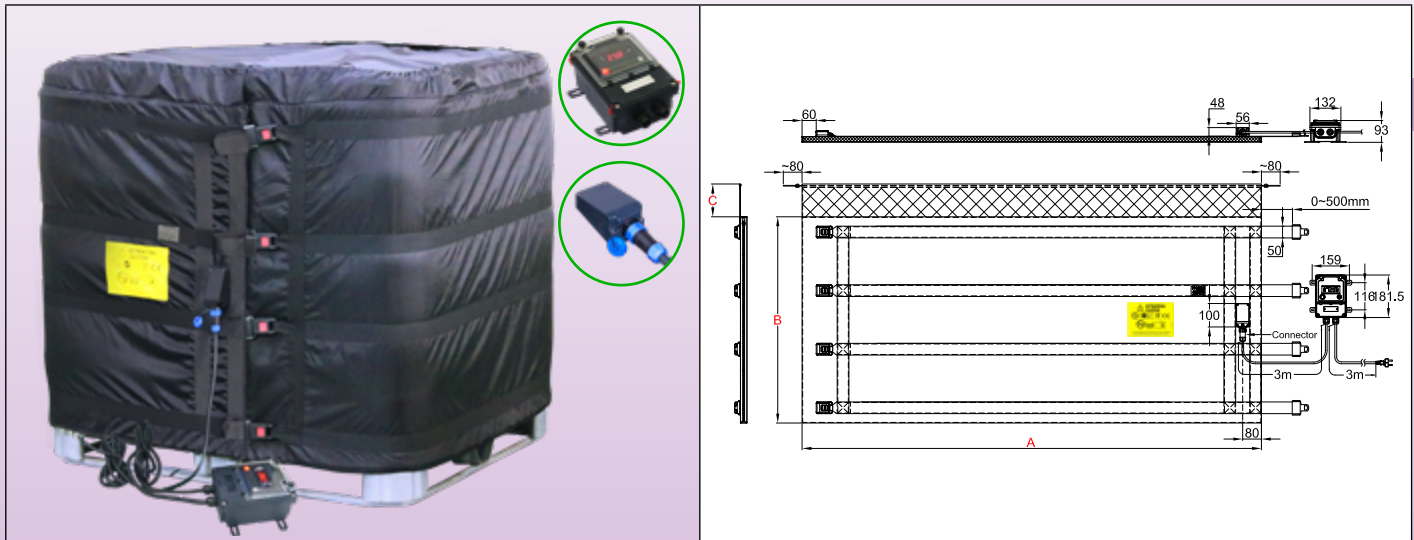

Because of permanent improvement of our products, drawings, descriptions, features used on these data sheets are for guidance only and can be modified without prior advice

Containers material	Maximum temperature limited to :	Tightening	Thermostat	Insulation thickness	Type
Plastic with tubular steel frame	65°C	Nylon straps and metal buckle	Remote electronic temperature controller	20mm	<b>9VJDF</b>



## Main Features

Thanks to its electronic digital temperature controller, adjustable up to 120°C, this series of flexible jacket heaters is mainly used for anti-freeze protection. This type of flexible jacket heaters is **the most professional solution, with a single temperature control for the entire heating mantle**. It is intended for 1000 liters bulk containers (IBC) of 1m x 1.20m and height 1m. **The wall mounting of the control box, as well as the quick connector ensuring the connection of this box on the jacket heater facilitate industrial use in a fixed working place in a production line.** The jacket heater covers the entire surface and is surmounted by a soft collar (Scarf) preventing sliding down. They are achievable with a **single power level: 0.05W/cm<sup>2</sup>**, for temperatures up to 50°C. Their insulation is 20mm thick. Their surface temperature is limited by two limiters at 65°. When used with a pedestal and an insulating lid (recommended), their energy efficiency can reach 90%.

## Technical characteristics

The heating element of the flexible jacket heater consists of a network of silicone insulated heating wires shielded by a metal braid, taken under a cover sewn in PU and Teflon coated polyester fabric. A 20mm thick, temperature-resistant NBR-PVC foam insulation is inserted between the heating network and the outer wall. This insulating foam has an insulation coefficient (Lambda  $\lambda$ ) of 0.039W/m.K, and this makes it possible to divide the energy losses by 3 compared to jacket heaters insulated with mineral wool or carbon fiber felt of the same thickness. Adjustable metal buckles allow quick assembly and disassembly and efficient clamping on the container. Their mechanical strength is exceptional.

### Fabric covering:

- Internal heating face: Teflon coated polyester fabric,
- External side: waterproof PU coated polyester fabric.

### Thermal insulation:

NBR-PVC foam, with closed cells and high temperature resistance, thickness 20mm.

### Heating element:

Silicon insulated heating wire with metal braid providing mechanical protection against puncturing and good grounding.

### Temperature control:

By electronic controller with digital display, On-Off action, relay output, located in an independent **waterproof** housing, **designed for wall mounting**. It is connected to the heating blanket by a cable equipped with a 5-pin **waterproof quick connector**, facilitating the connection and disconnection with the jacket heater. It controls the temperature by means of a thermistor probe placed on the inner surface of the fabric in contact with the container. This probe has an anticipation loop avoiding overheating. Two temperature limiters are incorporated in the heating net to limit the surface temperature to 50°C.

### Connection cable:

Insulated rubber power supply cable, for industrial environments, 3x1.5mm<sup>2</sup>, length 3m, with Euro plug. UL plug on request.

# Jacket heaters for 1000L IBC containers with tubular steel frame. **One heating zone.** **Digital display** electronic temperature controller, **remote wall mounting**



## Mounting on containers:

These jacket heaters feature nylon straps with quick-release adjustable buckles and a soft fabric collar without thermal insulation named scarf. This flexible scarf can be used to hold in place a flat insulating lid

## Options:

- Electronic thermostat temperature range -40+40°C
- Power supply 110/115V
- Power cord with industrial plug 2-pole + earth 16A CEE (IEC60309)
- Lids and insulating pedestals: see the accessories pages.

**Compliance with standards:** CE compliant. TUV certificate for EEC Low Voltage Directive (LVD) and EMC directive 2004/108/EC, and CE marked accordingly.

## Main references (see the technical introduction for the liquids heating time)

References*	Volume, US gallons	Volume, Liters	Dia. (mm ± 12; Inch ± 1/2")	Height <b>A</b> (mm/inch)	Flat length <b>B</b> (mm/inch)	Scarf <b>C</b> (mm/inch)	w/cm <sup>2</sup> (W/in <sup>2</sup> )	Max temp. °C	Watt	Voltage V
9VJDFAD398B205G	264	1000	1000 x 1200 (39.4 x 47.3)	1000 (39.4)	4390 (172.8)	100 (3.9)	0,05 (0.32)	50	2200	220/240

\*For these products supplied with UL plug and not Euro plug, replace the 15th character by X.

Because of permanent improvement of our products, drawings, descriptions, features used on these data sheets are for guidance only and can be modified without prior advice